

ZEUS: MRgRT Motion Management QA Phantom

Model 008Z

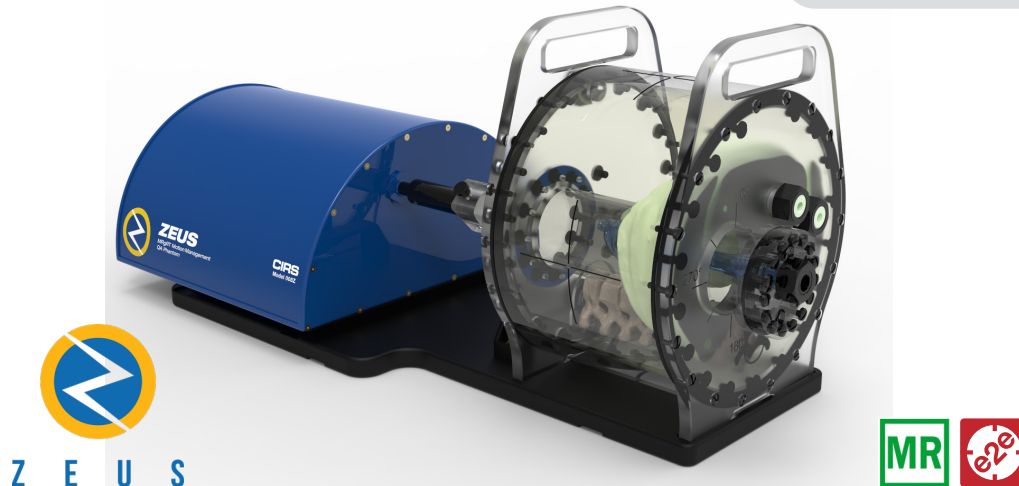

IMAGE ACQUISITION • TREATMENT PLANNING • DOSE DELIVERY

The integration of MR imaging in radiation therapy facilitates real time motion management.

The CIRS Zeus MRgRT Motion Management QA phantom is designed to address such needs. Zeus is MR Safe due to the use of piezoelectric motors and non-ferromagnetic materials. The two piezoelectric motors move a cylindrical insert, which contain a tracking target, through a gel/liquid fillable body by rotating it independently from the motion in the Inferior-Superior direction.

The moving insert contains an organic shaped target (tumor) filled with gel, which is surrounded by the same background gel used to fill the body. The body represents a heterogenous background due to simulated lungs, liver, kidney and spine. The simulated organs are anatomical in shape and have a life-like spatial relationship. They are filled with gels that provide contrast in CT and MR versus the background gel, which fills the void between the organs. Besides imaging, all organs, except for the lungs, offer ion chamber dosimetry cavities, which allow for completing an entire QA process; from imaging to planning to verification of dose delivered.

Zeus is designed as a single unit with a piezo actuator fixed permanently to a base plate on which the MRI body “snaps”. This allows for quick setup, removal, filling, and storage purposes. The phantom’s base plate has machined slots on the bottom, which allow for the use of indexing bars for precise and repeatable/reproducible phantom-MRI (MRI-Linac) alignment.

CIRS Motion Control software drives this phantom as well as the other phantoms from the CIRS dynamic family. In addition to multiple built-in motion profiles, which are more appropriate for commissioning and routine QA, the software allows for import of complex patient specific respiratory waveforms. These waveforms can be edited for amplitude, sample rate, cycle time, phase shift and baseline position. It also allows to setup independently controllable waveforms for linear and rotation motion of the insert. The Inferior-Superior motion of the insert/moving target can be gated based on amplitude to allow verification of beam latency. The motion controller box provides an interface (BNC physical input type) for the Beam-on Beam-off signal, which is read by the Motion Control software to calculate the Beam Latency specific to hybrid MRI-Linac systems.

Features & Benefits

- Piezoelectric motors, non-ferromagnetic materials => MR safe
- Easy setup, removal, alignment, positioning
- Organic shaped Organs at Risk and moving target
- Can be imaged in MRI, CT, PET and hybrid systems
- Ion chamber dosimetry in Liver, Kidney, Spine and moving target
- 3D tissue equivalent Spine for bone landmark
- Two independently programmable motions for the moving target
- Import, edit, and save patient specific breathing waveforms in addition to built-in QA waveforms
- Calculate beam latency from beam-on, beam-off signal

900 Asbury Ave • Norfolk, Virginia 23513 • USA
Tel: 800.617.1177 • 757.855.2765 • Fax: 757.857.0523

WWW.CIRSSINC.COM

CIRS

Tissue Simulation & Phantom Technology

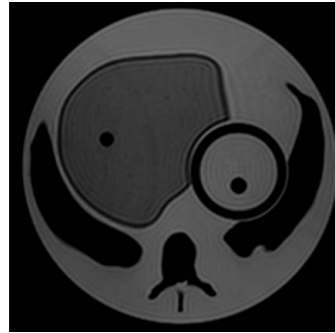
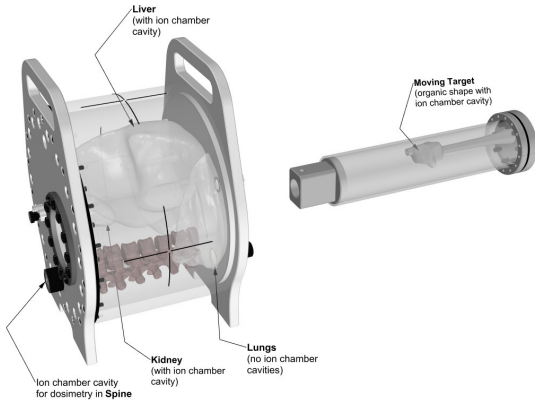

MRI

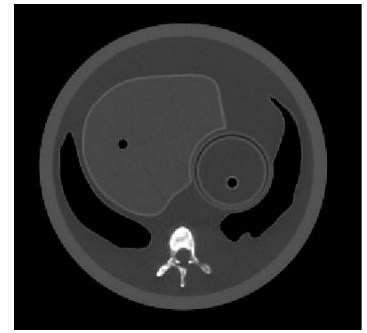

CT

SPECIFICATIONS

MOTION CONTROLLER

OVERALL DIMENSIONS:	67 cm x 32 cm x 20 cm
OVERALL WEIGHT:	12 kg (26.5 lbs)
AMPLITUDE, IS:	± 25 mm
AMPLITUDE, AP/LR:	± 3.5 mm
MOTION ACCURACY:	± 0.2 mm (linear motion)
MOTION ACCURACY:	± 0.25° (rotation motion)
CYCLE TIME:	1 - ∞ (adjusted based on amplitude)
WAVEFORMS:	sin (t), 1-2cos ⁴ (t), 1-2cos ⁶ (t), sawtooth, sharkfin (built in), custom (through import)

PHANTOM BODY*

OVERALL DIMENSIONS:	25.6 cm x 32 cm x 18 cm
OVERALL WEIGHT:	10 kg (22 lbs)

MOVING ROD*

OVERALL DIMENSIONS:	22 cm x Ø 6.3 cm
OVERALL WEIGHT:	1.1 kg (2.4 lbs)

Note: Customers must complete their order with the purchase of the moving rod. *Refer to separate CIRS cavity code list for available chamber cavities. It is recommended to choose the same cavities for both the body and rod.

INCLUDED WITH ZEUS

Part No.	Component Description
008Z	1 Zeus: MRgRT Motion Management QA phantom body (moving rod not included)
	1 Dynamic Motion Controller with firmware installed (110 - 220V, 50 - 60Hz)
	1 Actuator base plate assembly
	1 CIRS Motion Control Software
	1 Communication cables kit: Ethernet cable + adapter
	1 User's guide
	2 Carry Case

ADDITIONAL ITEMS FOR VIEWRAY SYSTEMS

	Component Description
Optional	Coil Support for ViewRay System (MRIdian)
Required	Low Pass RF Filter to Use with 008Z ViewRay System

USER FRIENDLY MOTION CONTROL

The intuitive graphical user interface provides an unlimited variety of motions while simplifying the operation of the phantom. Patient specific motion profiles are easily imported and there is no need to make hardware adjustments or have special programming skills. Beam latency testing can be performed without the need of an external oscilloscope.

