

DEXA Phantom

Model 026



THE "BONA FIDE PHANTOM" (BFP)⁽¹⁾

BioClinica's "Bona Fide Phantom" (BFP), is a quality control tool for Dual-Energy X-ray Absorptiometry (DEXA) instruments, which features an acrylic-embedded calcium hydroxyapatite (CHA) step-wedge. Advanced design features make it the best choice for assessing DEXA instrument stability. You can successfully use the BFP on all mainstream DEXA instruments.

The BFP offers a range of densities (0.7 - 1.5 g/cm²), to verify instrument function over the clinically relevant range, not just at a single, "healthy" bone mineral density (BMD). Linearity of BMD over the clinically range is critical for full instrument evaluation. The phantom uses a CHA insert for direct assessment of bone density accuracy. The CHA insert is compliant with FDA guidelines for cross-calibration phantoms for clinical trials.

The BFP is cast in acrylic and comes with its own carry case for easy handling. The tote remains on the phantom during scanning and does not affect BMD readings, allowing rapid placement and removal for the phantom from the bed. A flight case is available as an option.

Features

- Checks a Range of Densities
- FDA Compliant
- Easy to carry and can be Scanned in the Bag
- Universal Axial DEXA Instrument Compatibility
- No Water Bath
- Edge-Detection Challenge
- Realistic Soft Tissue Mimic

⁽¹⁾ BFP design is the property of BioClinica, Inc.

CIRS
Tissue Simulation & Phantom Technology

PEO B.V.

info@gotopeo.com
www.gotopeo.com

The Netherlands

Havenweg 16, 6603 AS Wijchen
+31 (0)24 648 86 88

Belgium

Watermolenstraat 2, B-2910 Essen
+32 (0)3 309 32 09

CoC 34107894
VAT NL807859151B01

IBAN NL29 RABO 0356 1960 46
BIC RABONL2U



DEXA PHANTOM

Model 026

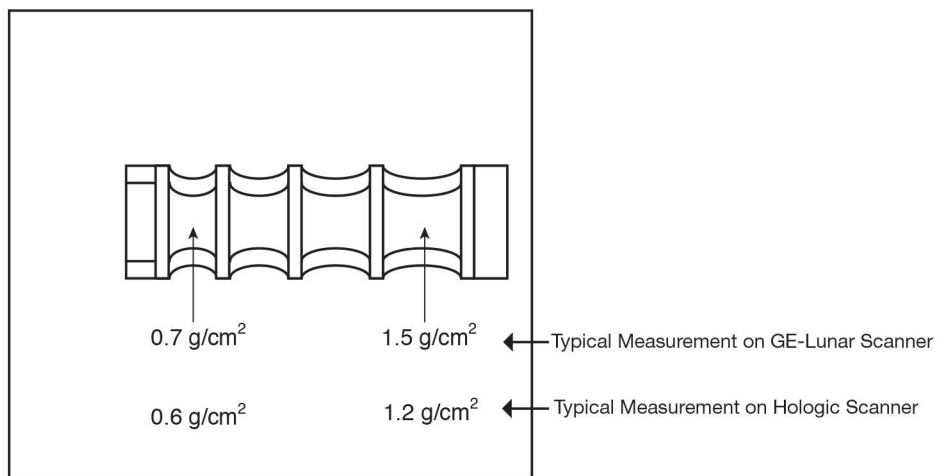

Note: The various DXA scanner manufacturers have developed and published cross-calibration formulas for use in data comparison.

SPECIFICATIONS

OVERALL DIMENSIONS	22 cm x 19 cm x 15 cm (8.7" x 7.5" x 6")
WEIGHT	17 lbs. (6.3 kg)
MATERIALS	<p>ACRYLIC EMBEDDED Calcium Hydroxyapatite</p> <p>SOFT TISSUE ANALOG Approximately 25 % Fat</p> <p>BMD RANGE 0.7 to 1.5 g/cm² (GE-Lunar) 0.6 to 1.2 g/cm² (Hologic)</p>

MODEL 026 INCLUDES

QTY	COMPONENT DESCRIPTION
1	DEXA Phantom
1	Carrying Case
1	User Guide
-	48-Month Warranty